

# The Bathroom Switch

The *NEW Bathroom Switch* follows our popular *Bathroom Switch* controller and is a new concept in “one”, “two” (or more) way light switch operation and consists of a small controller housing that can be hidden in the ceiling cavity, either behind the light rose or adjacent to a relevant junction box, allied to satellite *Sensor Pads*. These *Sensor Pads* can be adhered to the rear of most materials such as glass, plastic, ceramic tiles, metal and wood; and project a proximity sensing field through the material.

The *Sensor Pads* themselves operate on only 5volts DC, and can utilize existing cabling. Only 2 wires per switch are used. The PCB of the *Sensor Pad* is no bigger than a postage stamp so the switching sites can be very un-obtrusive if necessary. This means that the cabling within the walls is only carrying this low voltage and is therefore very safe. Up-to 6 *Sensor Pads* can be used to operate each controller and there is the provision to include an additional conventional switch in the circuit. (see separate installation instructions).

The *Bathroom Switch* circuit uses a relay that is contained within the controller housing to operate the switching function.. Operating the *Bathroom Switch* is simple: Touch your chosen faceplate (tile etc.) and the lights will turn on. Touch again to switch off.

## Wiring Instructions,

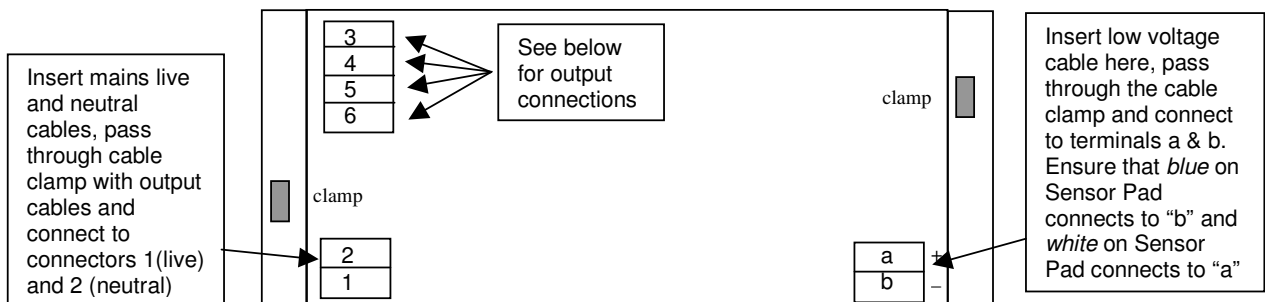

## Output Connections,(these connection details are also on the inside lid of the housing)

- 3 Relay Common
- 4 Relay Normally closed
- 5 Relay Normally open (use this for normal live output to lights)
- 6 Neutral output

## Bathroom Zones

The 17th Edition of the IEE Wiring Regulations redefined the zones for electrical equipment in bathrooms and must be used for installations designed after 30th June 2008. They are now identified from 0 to 2, with 0 being the wettest - the previous zone 3 is no longer defined.

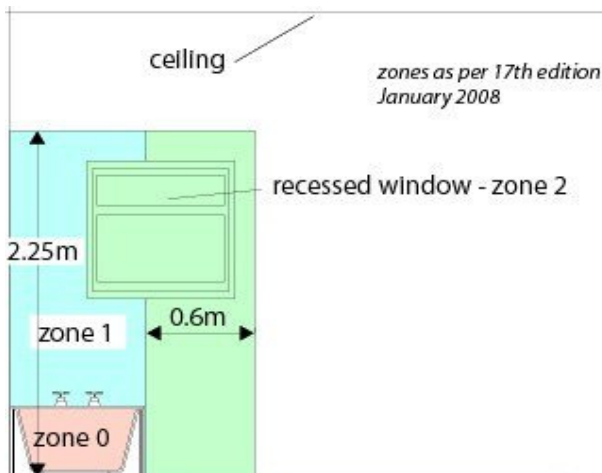

**Zone 0** The interior of the bath or shower which can hold water.

**Zone 1** The area directly above zone 0 limited vertically to 2.25m above the bottom of the bath or shower. Also 1.2m horizontally from the centre of a shower outlet to the height of the outlet or 2.25m whichever is the higher.

**Zone 2** The area beyond zones 0 and 1, 0.6m horizontally and up to 2.25m vertically. Zone 2 also included any recessed window with a sill next to the bath.

**Note:** Providing that the space under the bath cannot be accessed without using tools (i.e. screwdriver etc), that space is considered to be 'out of scope'.

Please see overleaf for wiring diagram and specifications

## Wiring layout for Bathroom Switch:

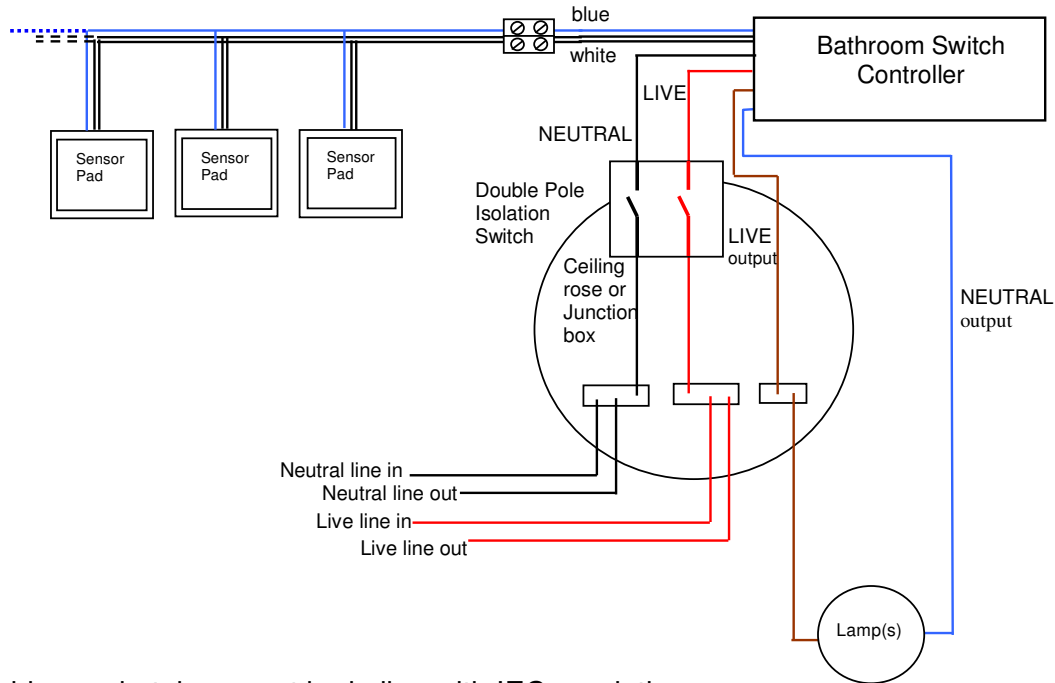

All wiring undertaken must be in line with IEC regulations

### Uses:

The *Bathroom Switch Controller* can be used to operate most types of lighting including low voltage transformers; It is also suitable for use with fluorescent lighting, including low energy bulbs. **Please do not exceed the switching capability of the controller (500Watts)**, if this loading is exceeded, the controller will shut down **permanently**.

### Installation:

#### Controller:

The *Bathroom Switch Controller* should be mounted in an accessible position outside any bathroom zones, (please see information on zones), and supplied through a double pole isolation switch. All wires should always be routed through the internal cable clamps and inserted into the correct connections. The *Bathroom Switch Controller* should never be covered with any thermal insulation material. **All mains wiring should be undertaken by a qualified electrician and be in line with IEC regulations.** Please ensure that power is switched **OFF** prior to working with any mains electrical product. Note to installers – *The Bathroom Switch Controller* is intended for fixed installation only.

#### Sensor Pads:

The low voltage cables and *Sensor Pads* can be fitted and wired by competent DIYers; this means that if necessary, installation of the *Sensor Pads* can be undertaken by an un-qualified person (DIY) whilst, for example, tiling is being done. Please see separate installation instructions accompanying your *Sensor Pads*. **All mains wiring must be undertaken by a qualified electrician.**

### Specifications:

Controller Operating voltage	220 – 240 vac 50Hz (110 vac available on request)
Sensor Pad voltage	5 vdc
Max. Controller switching capacity	500 Watts
Max. Ambient temperature	35° C
Controller Dimensions	140 x 56 x 32mm
Sensor Pad PCB Dims.	22.5 x 18.5 x 3.5mm