

The Bathroom Dimmer Switch with Time Delay

The *Bathroom Dimmer/Timer Switch* follows our popular *Bathroom Switch* controller and is a new concept in “one”, “two” (or more) way light switch operation and consists of a small controller housing that can be hidden in the ceiling cavity, either behind the light rose or adjacent to a relevant junction box, allied to satellite *Sensor Pads*. These *Sensor Pads* can be adhered to the rear of most materials such as glass, plastic, ceramic tiles, metal and wood; and project a proximity sensing field through the material.

The *Sensor Pads* themselves operate on only 5volts DC, and can utilize existing cabling. Only 2 wires per switch are used. The PCB of the *Sensor Pad* is no bigger than a postage stamp so the switching sites can be very un-obtrusive if necessary. This means that the cabling within the walls is only carrying this low voltage and is therefore very safe. Up-to 6 *Sensor Pads* can be used to operate each controller.

The *Bathroom Dimmer/Timer Switch* circuit uses a relay that is contained within the controller housing to operate the switching function. The delay in switch-off can be varied by rotating the internal timer; clockwise increases delay and anti-clockwise decreases delay. Operating the *Bathroom Dimmer/Timer Switch* is simple: Touch your chosen faceplate (tile etc.) and the lights will turn on at low level, keep touching and the lights will begin to ramp up to full brightness, remove the hand and the lights will stay at the intensity reached. To switch off, touch briefly and the lights will ramp down to off when the set time has expired. If required, a further touch during this ramp-down will again latch to the intensity reached. By removing the momentary link (see below), the controller will time out without a second touch.

Wiring Instructions,

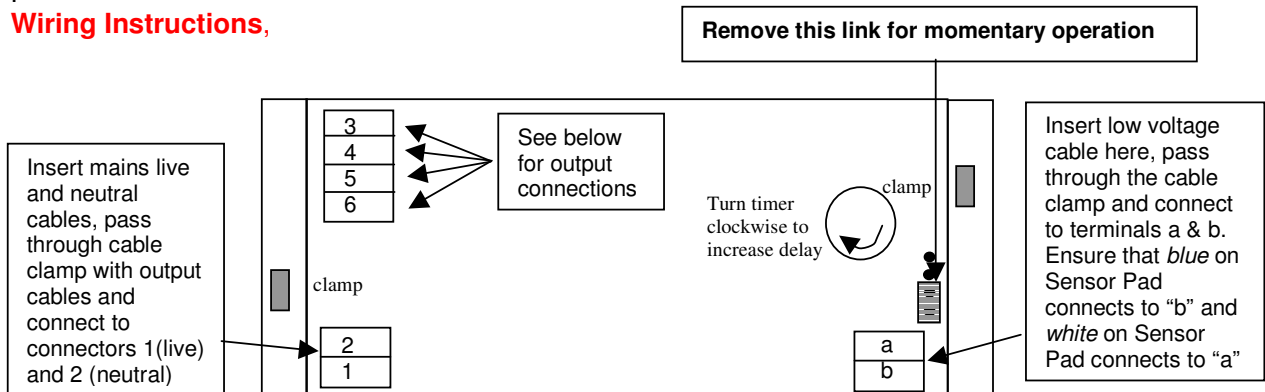

Output Connections, (these connection details are also on the inside lid of the housing)

- 3 Relay Common
- 4 Relay Normally closed
- 5 Relay normally open (use this for normal live output to lights)
- 6 Neutral output

Bathroom Zones

The 17th Edition of the IEE Wiring Regulations redefined the zones for electrical equipment in bathrooms and must be used for installations designed after 30th June 2008. They are now identified from 0 to 2, with 0 being the wettest - the previous zone 3 is no longer defined.

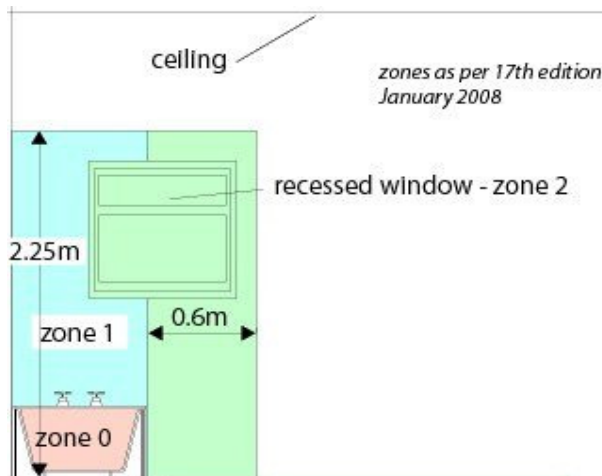

Zone 0 The interior of the bath or shower which can hold water.

Zone 1 The area directly above zone 0 limited vertically to 2.25m above the bottom of the bath or shower. Also 1.2m horizontally from the centre of a shower outlet to the height of the outlet or 2.25m whichever is the higher.

Zone 2 The area beyond zones 0 and 1, 0.6m horizontally and up to 2.25m vertically. Zone 2 also included any recessed window with a sill next to the bath.

Note: Providing that the space under the bath cannot be accessed without using tools (i.e. screwdriver etc), that space is considered to be 'out of scope'.

Please see overleaf for wiring diagram and specifications

Wiring layout for Bathroom Dimmer Timer Switch:

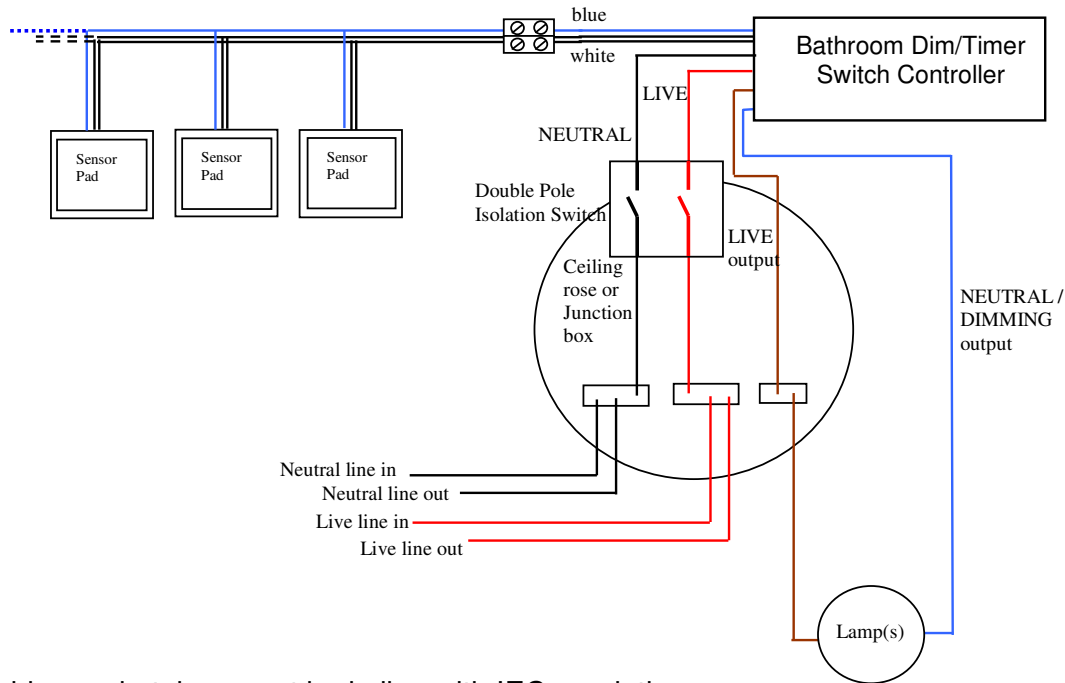

All wiring undertaken must be in line with IEC regulations

Uses:

The Bathroom Dimmer/Timer Switch Controller can be used to operate most types of lighting including low voltage transformers; It is also suitable for use with fluorescent lighting, including low energy bulbs.

Please do not exceed the switching capability of the controller (350Watts), if this loading is exceeded, the controller will shut down **permanently**.

Installation:

Controller:

The Bathroom Dimmer/Timer Switch Controller should be mounted in an accessible position outside any bathroom zones, (please see information on zones), and supplied through a double pole isolation switch. All wires should always be routed through the internal cable clamps and inserted into the correct connections. The Bathroom Dimmer/Timer Switch Controller should never be covered with any thermal insulation material. **All mains wiring should be undertaken by a qualified electrician and be in line with IEC regulations.** Please ensure that power is switched **OFF** prior to working with any mains electrical product. Note to installers – The Bathroom Dimmer/Timer Switch Controller is intended for fixed installation only.

Sensor Pads:

The low voltage cables and Sensor Pads can be fitted and wired by competent DIYers; this means that if necessary, installation of the Sensor Pads can be undertaken by an un-qualified person (DIY) whilst, for example, tiling is being done. Please see separate installation instructions accompanying your Sensor Pads. **All mains wiring must be undertaken by a qualified electrician.**

Specifications:

| | |
|------------------------------------|---|
| Controller Operating voltage | 220 – 240 vac 50Hz (110 vac available on request) |
| Sensor Pad voltage | 5 vdc |
| Max. Controller switching capacity | 350 Watts |
| Max. Ambient temperature | 35° C |
| Controller Dimensions | 140 x 56 x 32mm |
| Sensor Pad PCB Dims. | 22.5 x 18.5 x 3.5mm |